



Custom Mining Products

ABN 90169702087

VENTILATION STOPPING SERVICES VALVE

For more information visit our web site:
www.customminingproducts.com

REG. DESIGN

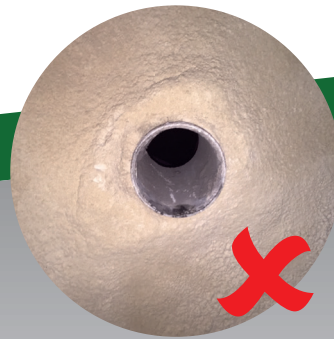
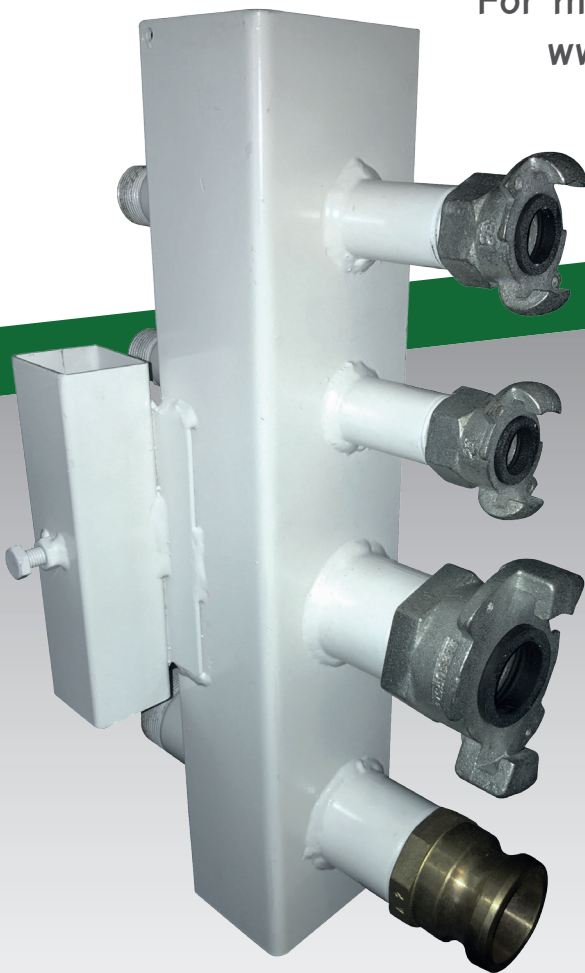

Developed to dramatically reduce ventilation loss in Underground Mine Development panels and long wall blocks. This simple but effective solution comes ready to mount and be sprayed into position when building your next ventilation stopping.

Instead of the current methods of:

- ✗ Spraying a short piece of 6 inch pipe in and trying to seal with rag once the hoses are put through
- ✗ Putting service hoses through the small inspection hole in the door
- ✗ Opening the door slightly so the hoses can go through

- Solid but light weight steel construction.
- No moving parts and easy to install
- Australian designed and made.
- Has 4 through pipes 2 x 2 inch and 2 x 1 inch (different variations available upon request)
- The ends of each through pipe comes threaded for valves – minsup or camlock fittings (not supplied)
- Designed so stopping material can be easily sprayed in and around the valve for strength
- Adjustable mounting block that slides easily over the stopping uprights, holding it into position while stopping is being built.

OPL Mining Pty Ltd

☎ 0428 374 367

✉ info@customminingproducts.com